



Revolution Products

PARK AVENUE LIBRARY FURNITURE

PRICE LIST 2025

PLEASE ADD 25% TO ALL LIST PRICES IN THIS CATALOG EFFECTIVE 12/1/25



Revolution Products
259 Whip O Will Drive
Clinton, SC 29325
864-547-5727

Park Avenue

Welcome to Park Avenue from Revolution Products.

Index

- I. Terms and Conditions

- II. **PARK AVENUE** Reading Tables Pgs. 3-4
with square tapered legs
- III. **PARK AVENUE** IT Tables with monitor racks Pg. 5
with square tapered legs
- IV. **PARK AVENUE** IT Tables with Sentinel end Pgs. 6-7
frame, monitor racks and square tapered legs
- IV. **PARK AVENUE** Tables with Sentinel end Pg. 8-9
frame and square tapered legs
- V. **PARK AVENUE** Post and Panel Carrels Pgs. 10-11
with square tapered legs
- VI. **PARK AVENUE** Full Panel Carrels Pgs. 12-13
with square tapered legs
- VII. **PARK AVENUE** Reading Tables Pgs. 14-15
with round tapered legs
- VIII. **PARK AVENUE** IT Tables with monitor racks Pg. 16
with round tapered legs
- IX. **PARK AVENUE** Post and Panel Carrels Pgs. 17-18
with round tapered legs
- X. **PARK AVENUE** Full Panel Carrels Pgs. 19-20
with round tapered legs
- XI. **PARK AVENUE** End Panels Pgs. 21-25
- XI. **PARK AVENUE** Product Drawings Pgs. 26-28

Park Avenue

Terms of Sale: All prices are FOB Clinton, SC. Net 30 days from date of shipment. All prices are list and subject to change without notice. Interest of 2% per month will be assessed on past due invoices. Possession of price list does not constitute authority to purchase or sell products herein.

Taxes: All applicable taxes are extra. If a client is tax exempt please provide tax certificate.

Ordering: Orders must have all pertinent information provided before they will be processed and entered including model numbers, quantities and finish, laminate and fabric selections where appropriate. Please provide a requested by date, or not to ship before date on your order.

Warranty: All items are warranted for 10 years unless otherwise stated. Warranty is for initial purchaser and only valid as long as the product is owned by original customer. The warranty, which begins at date of manufacture, covers defects in materials and workmanship found during the normal usage of product during the warranty period. Revolution Products will at its option repair or replace the defective product with a comparable component or product. Warranty does not cover any "Customers Own Material" used in manufacture. Except as stated above, Revolution Products makes no express or implied warranties as to any product and in particular makes no warranty of fitness for any particular use. At Revolution Products option, product repair, or replacement is the customer's exclusive remedy for any and all product defects.

BIFMA and ANSI Testing: All products offered by Revolution Products meet or exceed applicable BIFMA and ANSI testing standards.

New Accounts: New Accounts can only be established with the approval of a Revolution Products representative. New accounts will be subject to special credit reference requirements and deposit terms before they are approved.

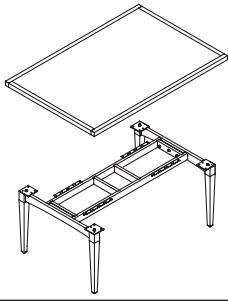

Park Avenue

READING TABLES WITH SQUARE TAPERED LEGS

MODEL NUMBER	DESCRIPTION	LIST PRICE
PS-3648-O-T	Table 36" deep x 48" wide in oak, HPL top 1 1/4" thick with 1 3/4" W X 1 5/8" H drop edge banding, 3" arched aprons at the ends, 2 3/4" solid oak square legs tapered to 1 1/2" at the bottom, metal leg plates, and ladder keel for structural support	4462.00
PS-3060-O-T	Table 30" deep x 60" wide in oak, HPL top 1 1/4" thick with 1 3/4" W x 1 5/8" H drop edge banding, 3" arched aprons at the ends, 2 3/4" solid oak square legs tapered to 1 1/2" at the bottom, metal leg plates, and ladder keel for structural support	4763.00
PS-3660-O-T	Table 36" deep x 60" wide in oak, HPL top 1 1/4" thick with 1 3/4" W x 1 5/8" H drop edge banding, 3" arched aprons at the ends, 2 3/4" solid oak square legs tapered to 1 1/2" at the bottom, metal leg plates, and ladder keel for structural support	4878.00
PS-3672-O-T	Table 36" deep x 72" wide in oak, HPL top 1 1/4" thick with 1 3/4" W x 1 5/8" H drop edge banding, 3" arched aprons at the ends, 2 3/4" solid oak square legs tapered to 1 1/2" at the bottom, metal leg plates, and ladder keel for structural support	5302.00
PS-3696-O-T	Table 36" deep x 96" wide in oak, HPL top 1 1/4" thick with 1 3/4" W x 1 5/8" H drop edge banding, 3" arched aprons at the ends, 2 3/4" solid oak square legs tapered to 1 1/2" at the bottom, metal leg plates, and ladder keel for structural support	6133.00
PS-4272-O-T	Table 42" deep x 72" wide in oak, HPL top 1 1/4" thick with 1 3/4" W x 1 5/8" H drop edge banding, 3" arched aprons at the ends, 2 3/4" solid oak square legs tapered to 1 1/2" at the bottom, metal leg plates, and ladder keel for structural support	5534.00
PS-4296-O-T	Table 42" deep x 96" wide in oak, HPL top 1 1/4" thick with 1 3/4" W x 1 5/8" H drop edge banding, 3" arched aprons at the ends, 2 3/4" solid oak square legs tapered to 1 1/2" at the bottom, metal leg plates, and ladder keel for structural support	6382.00
PS-4872-O-T	Table 48" deep x 72" wide in oak, HPL top 1 1/4" thick with 1 3/4" W x 1 5/8" H drop edge banding, 3" arched aprons at the ends, 2 3/4" solid oak square legs tapered to 1 1/2" at the bottom, metal leg plates, and ladder keel for structural support	5733.00
PS-4896-O-T	Table 48" deep x 96" wide in oak, HPL top 1 1/4" thick with 1 3/4" W x 1 5/8" H drop edge banding, 3" arched aprons at the ends, 2 3/4" solid oak square legs tapered to 1 1/2" at the bottom, metal leg plates, and ladder keel for structural support	6560.00

Park Avenue

READING TABLES WITH SQUARE TAPERED LEGS

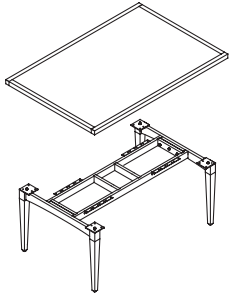

MODEL NUMBER	DESCRIPTION	LIST PRICE
PS-4242-O-T	Table 42" square in oak, HPL top 1 1/4" thick with 3/4" W x 1 5/8" H oak drop edge banding, 3" arched aprons on 2 ends, 2 3/4" solid oak square legs tapered to 1 1/2" at the bottom with metal leg plates, ladder keel for structural support	4169.00
PS-4848-O-T	Table 48" square in oak, HPL top 1 1/4" thick with 3/4" W x 1 5/8" H oak drop edge banding, 3" arched aprons, 2 3/4" solid oak square legs tapered to 1 1/2" at the bottom with metal leg plates, ladder keel for structural support	4229.00
PS-42R-O-T	Table 42" round in oak, HPL top 1 1/4" thick with 3/4" W x 1 5/8" H oak drop edge banding, 3" arched aprons, 2 3/4" solid oak square legs tapered to 1 1/2" at the bottom with metal leg plates	4742.00
PS-48R-O-T	Table 48" round in oak, HPL top 1 1/4" thick with 3/4" W x 1 5/8" H oak drop edge banding, 3" arched aprons, 2 3/4" solid oak square legs tapered to 1 1/2" at the bottom with metal leg plates	5182.00
PS-60R-O-T	Table 60" round in oak, HPL top 1 1/4" thick with 3/4" W x 1 5/8" H oak drop edge banding 3" arched aprons, 2 3/4" solid oak square legs tapered to 1 1/2" at the bottom with metal leg plates	5583.00
SUFFIX -M	For maple change the suffix O to M and add 7 percent.	

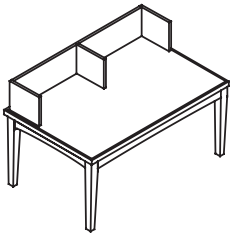

Park Avenue

IT TABLES WITH MONITOR RACKS AND SQUARE TAPERED LEGS

MODEL NUMBER	DESCRIPTION	LIST PRICE
PS-3036-O-IT	Information technology table 30" deep x 36" wide in oak, HPL top 1 1/4" T with 1 3/4" W x 1 5/8" H drop edge banding, 3" arched aprons at the ends, 2 3/4" solid oak square legs tapered to 1 1/2" at the bottom, metal leg plates and ladder keel, 10" high monitor rack at the back of the table and extending forward 10" at each end	4840.00
PS-3048-O-IT	Information technology table 30" deep x 48" wide in oak, HPL top 1 1/4" T with 1 3/4" W x 1 5/8" H drop edge banding, 3" arched aprons at the ends, 2 3/4" solid oak square legs tapered to 1 1/2" at the bottom, metal leg plates and ladder keel, 10" high monitor rack at the back of the table and extending forward 10" at each end	5024.00
PS-3060-O-IT	Information technology table 30" deep x 60" wide in oak, HPL top 1 1/4" T with 1 3/4" W x 1 5/8" H drop edge banding, 3" arched aprons at the ends, 2 3/4" solid oak square legs tapered to 1 1/2" at the bottom, metal leg plates and ladder keel, 10" high monitor rack at the back of the table and extending forward 10" at each end	5435.00
PS-3072-O-IT	Information technology table 30" deep x 72" wide in oak, HPL top 1 1/4" T with 1 3/4" W x 1 5/8" H drop edge banding, 3" arched aprons at the ends, 2 3/4" solid oak square legs tapered to 1 1/2" at the bottom, metal leg plates and ladder keel, 10" high monitor rack at the back of the table and extending forward 10" at each end	5953.00
PS-3072-O-IT2	Information technology table 30" deep x 72" wide in oak, HPL top 1 1/4" T with 1 3/4" W x 1 5/8" H drop edge banding, 3" arched aprons at the ends, 2 3/4" solid oak square legs tapered to 1 1/2" at the bottom, metal leg plates and ladder keel, 10" high monitor rack at the back of the table and extending forward 10" at each end and the center point dividing the unit intop 2 work spaces	6054.00
PS-3096-O-IT2	Information technology table 30" deep x 96" wide in oak, HPL top 1 1/4" T with 1 3/4" W x 1 5/8" H drop edge banding, 3" arched aprons at the ends, 2 3/4" solid oak square legs tapered to 1 1/2" at the bottom, metal leg plates and ladder keel, 10" high monitor rack at the back of the table and extending forward 10" at each end and the center point dividing the unit intop 2 work spaces	7012.00
PS-3096-O-IT3	Information technology table 30" deep x 96" wide in oak, HPL top 1 1/4" T with 1 3/4" W x 1 5/8" H drop edge banding, 3" arched aprons at the ends, 2 3/4" solid oak square legs tapered to 1 1/2" at the bottom, metal leg plates and ladder keel, 10" high monitor rack at the back of the table and extending forward 10" at each end and 2 center points dividing the unit intop 3 work spaces	7113.00

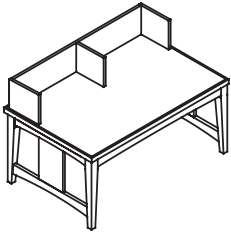

Park Avenue

IT TABLES WITH MONITOR RACKS,
SENTINEL ENDS AND SQUARE
TAPERED LEGS

MODEL NUMBER	DESCRIPTION	LIST PRICE
PS-3096-O-ITS2	Information technology table 30" deep x 96" wide in oak, HPL top 1 1/4" T with 1 3/4" W x 1 5/8" H drop edge banding, Sentinel ends consisting of a 3" high arched apron, a 3" high arched stretcher, a solid vertical panel and 2 slats, 2 3/4" solid oak square legs tapered to 1 1/2" at the bottom with metal plates, ladder keel, 10" high monitor rack at the back of the table and extending forward 10" at each end and the center	9772.00
PS-3096-O-ITS3	Information technology table 30" deep x 96" wide in oak, HPL top 1 1/4" T with 1 3/4" W x 1 5/8" H drop edge banding, Sentinel ends consisting of a 3" high arched apron, a 3" high arched stretcher, a solid vertical panel and 2 slats, 2 3/4" solid oak square legs tapered to 1 1/2" at the bottom with metal plates, ladder keel, 10" high monitor rack at the back of the table and extending forward 10" at each end and 2 center points dividing the table into 3 equal work spaces	9875.00

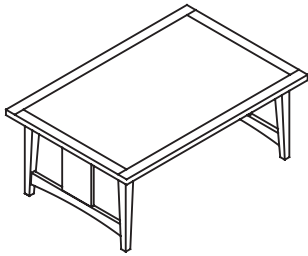

Park Avenue

TABLES WITH SENTINEL ENDS FRAME AND SQUARE TAPERED LEGS

MODEL NUMBER	DESCRIPTION	LIST PRICE
PS-3648-O-TS	Table 36" deep x 48" wide in oak, HPL top 1 1/4" thick with 1 3/4" W x 1 5/8" T drop edge banding, Sentinel ends consisting of a 3" high arched apron, a 3" high arched stretcher, a solid vertical panel and 2 slats, 2 3/4" solid oak square legs tapered to 1 1/2" at the bottom with metal leg plates, ladder keel for structural support	5915.00
PS-3060-O-TS	Table 30" deep x 60" wide in oak, HPL top 1 1/4" thick with 1 3/4" W x 1 5/8" T drop edge banding, Sentinel ends consisting of a 3" high arched apron, a 3" high arched stretcher, a solid vertical panel and 2 slats, 2 3/4" solid oak square legs tapered to 1 1/2" at the bottom with metal leg plates, ladder keel for structural support	5988.00
PS-3660-O-TS	Table 36" deep x 60" wide in oak, HPL top 1 1/4" thick with 1 3/4" W x 1 5/8" H drop edge banding, Sentinel ends consisting of a 3" high arched apron, a 3" high arched stretcher, a solid vertical panel and 2 slats, 2 3/4" solid oak square legs tapered to 1 1/2" at the bottom with metal leg plates, ladder keel for structural support	6429.00
PS-3672-O-TS	Table 36" deep x 72" wide in oak, HPL top 1 1/4" thick with 1 3/4" W x 1 5/8" H drop edge banding, Sentinel ends consisting of a 3" high arched apron, a 3" high arched stretcher, a solid vertical panel and 2 slats, 2 3/4" solid oak square legs tapered to 1 1/2" at the bottom with metal leg plates, ladder keel for structural support	6752.00
PS-3696-O-TS	Table 36" deep x 96" wide in oak, HPL top 1 1/4" thick with 1 3/4" W x 1 5/8" H drop edge banding, Sentinel ends consisting of a 3" high arched apron, a 3" high arched stretcher, a solid vertical panel and 2 slats, 2 3/4" solid oak square legs tapered to 1 1/2" at the bottom with metal leg plates, ladder keel for structural support	7427.00
PS-4272-O-TS	Table 42" deep x 72" wide in oak, HPL top 1 1/4" thick with 1 3/4" W x 1 5/8" H drop edge banding, Sentinel ends consisting of a 3" high arched apron, a 3" high arched stretcher, a solid vertical panel and 2 slats, 2 3/4" solid oak square legs tapered to 1 1/2" at the bottom with metal leg plates, ladder keel for structural support	7034.00
PS-4296-O-TS	Table 42" deep x 96" wide in oak, HPL top 1 1/4" thick with 1 3/4" W x 1 5/8" H drop edge banding, Sentinel ends consisting of a 3" high arched apron, a 3" high arched stretcher, a solid vertical panel and 2 slats, 2 3/4" solid oak square legs tapered to 1 1/2" at the bottom with metal leg plates, ladder keel for structural support	7710.00

Park Avenue

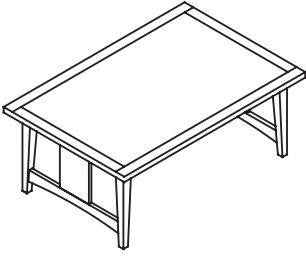

PS-4872-O-TS	Table 48" deep x 72" wide in oak, HPL top 1 1/4" thick with 1 3/4" W x 1 5/8" H drop edge banding, Sentinel ends consisting of a 3" high arched apron, a 3" high arched stretcher, a solid vertical panel and 2 slats, 2 3/4" solid oak square legs tapered to 1 1/2" at the bottom with metal leg plates, ladder keel for structural support	7630.00
PS-4896-O-TS	Table 48" deep x 96" wide in oak, HPL top 1 1/4" thick with 1 3/4" W x 1 5/8" H drop edge banding, Sentinel ends consisting of a 3" high arched apron, a 3" high arched stretcher, a solid vertical panel and 2 slats, 2 3/4" solid oak square legs tapered to 1 1/2" at the bottom with metal leg plates, ladder keel for structural support	8469.00

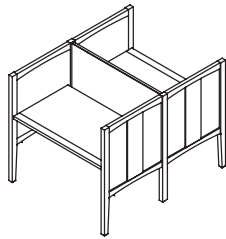

Park Avenue

POST AND PANEL CARRELS WITH SQUARE TAPERED LEGS

MODEL NUMBER	DESCRIPTION	LIST PRICE
PS-3136-O-PPSC	Elevated Panel Carrel work station starter in oak 31" deep x 38" wide x 48" high, 1 1/8" thick end panels with 2 1/2" high solid oak arched edge banding at the top and bottom of the panels with 5" wide center slat, 2" wide flat posts tapered on 2 sides from the bottom of the panel to 1 1/2" at the floor, 1 1/4" thick HPL work surface with 1 3/4" W oak edge banding	5073.00
PS-3136-O-PPSCA	Carrel work station adder in oak 31" deep x 36 1/2" wide x 48" high, 1 1/8" thick intermediate panel with arched detailing at the top and bottom of the panel, 2" wide flat posts tapered on 2 sides from the bottom of the panel to 1 1/2" at the floor, 1 1/4" thick HPL work surface with 1 3/4" thick edge oak banding	3954.00
PSD-3150-O-PPSC	Elevated Panel Carrel work station starter in oak 31" deep x 50" wide x 48" high, 1 1/8" thick end panels with 2 1/2" high solid oak arched edge banding at the top and bottom of the panel with 5" wide center slat, 2" wide flat posts tapered on 2 sides from the bottom of the panel to 1 1/2" at the floor, 1 1/4" thick HPL work surface with 1 3/4" W oak edge banding	5838.00
PS-3148-O-PPSCA	Carrel work station adder in oak 31" deep x 48 1/2" wide x 48" high, 1 1/8" thick intermediate panel with arched detailing at the top and bottom of the panel, 2" wide flat posts tapered on 2 sides from the bottom of the panel to 1 1/2" at the floor, 1 1/4" thick HPL work surface with 1 3/4" thick edge oak banding	4719.00
PS-3136-O-PPDF	Elevated Panel Carrel work station, double faced, starter in oak 61" deep x 38" wide x 48" high, 1 1/8" thick end panels with 2 1/2" high solid oak arched edge banding at top and bottom of panels with 5" wide center slat, 2" wide flat posts tapered on 2 sides from the bottom of the panel to 1 1/2" at the floor, 2 each 1 1/4" thick HPL work surfaces with 1 3/4" thick edge banding	8482.00
PS-3136-O-PPDFA	Carrel work station, double faced, adder in oak 61" deep x 36 1/2" wide x 48" high, 1 1/8" thick intermediate panels with arched detailing at the top and bottom of the panel, 2" wide flat posts tapered on 2 sides from the bottom of the panel to 1 1/2" at the floor, 2 each 1 1/4" thick HPL work surface with 1 3/4" thick oak edge banding	6678.00

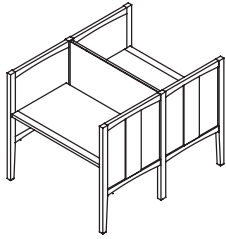

Park Avenue

POST AND PANEL CARRELS WITH SQUARE TAPERED LEGS

MODEL NUMBER	DESCRIPTION	LIST PRICE
PS-3148-O-PPDF	Elevated Panel Carrel work station, double faced, starter in oak 61" deep x 50" wide x 48" high, 1 1/8" thick end panels with 2 1/2" high solid oak arched edge banding at top and bottom of panels with 5" wide center slat, 2" wide flat posts tapered on 2 sides from the bottom of the panel to 1 1/2" at the floor, 2 each 1 1/4" thick HPL work surfaces with 1 3/4" thick edge banding	9562.00
PS-3148-O-PPDFA	Carrel work station, double faced, adder in oak 61" deep x 48 1/2" wide x 48" high, 1 1/8" thick intermediate panels with arched detailing at the top and bottom of the panels, 2" wide flat posts tapered on 2 sides from the bottom of the panel to 1 1/2" at the floor, 2 each 1 1/4" thick HPL work surface with 1 3/4" thick oak edge banding	7364.00
SHELF	For each book shelf at 210.00.	
SUFFIX -M	For maple change the suffix O to M and add 7 percent.	

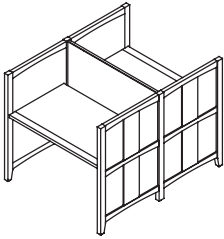

Park Avenue

FULL PANEL CARRELS WITH SQUARE TAPERED LEGS

MODEL NUMBER	DESCRIPTION	LIST PRICE
PS-3136-O-FPSC	Elevated Panel Carrel work station starter in oak 31" deep x 38" wide x 48" high, 1 1/8" thick end panels with 2 1/2" high solid oak arched edge banding at the top and bottom of the end panels with horizontal center slat and 5" wide vertical slats, 2" flat end posts tapered on 2 sides from the bottom of the panel to 1 1/2" at the floor, 1 1/4" thick HPL work surface with 1 3/4" wide oak edge banding	5690.00
PS-3136-O-FPSCA	Carrel work station adder in oak 31" deep x 36 1/2" wide x 48" high, 1 1/8" thick intermediate panel with arched detailing at the top and bottom of the panel, 2" flat end posts tapered on 2 sides from the bottom of the panel to 1 1/2" at the floor, 1 1/4" thick HPL work surface with 1 3/4" thick oak edge banding	4553.00
PS-3150-O-FPSC	Elevated Panel Carrel work station starter in oak 31" deep x 50" wide x 48" high, 1 1/8" thick end panels with 2 1/2" high solid oak arched edge banding at the top and bottom of the end panels with horizontal center slat and 5" wide vertical slats, 2" flat end posts tapered on 2 sides from the bottom of the panel to 1 1/2" at the floor, 1 1/4" thick HPL work surface with 1 3/4" wide oak edge banding	6455.00
PS-3148-O-FPSCA	Carrel work station adder in oak 31" deep x 48 1/2" wide x 48" high, 1 1/8" thick intermediate panel with arched detailing at the top and bottom of the panel, 2" flat end posts tapered on 2 sides from the bottom of the panel to 1 1/2" at the floor, 1 1/4" thick HPL work surface with 1 3/4" thick oak edge banding	5315.00
PS-3136-O-FPDF	Elevated Panel Carrel work station, double faced, starter in oak 61" deep x 38" wide x 48" high, 1 1/8" thick end panels with 2 1/2" high solid oak arched edge banding at the top and bottom of the end panels with horizontal center slat and 5" wide vertical slats, 2" flat end posts tapered from the bottom of the panel to 1 1/2" at the floor, 2 each 1 1/4" thick HPL work surfaces with 1 3/4" thick oak edge banding	9542.00
PS-3136-O-FPDFA	Carrel work station, double faced, adder in oak 61" deep x 36 1/2" wide x 48" high, 1 1/8" thick intermediate panels with arched detailing at the top and bottom of the panel, 2" flat end posts tapered from the bottom of the to 1 1/2" at the floor, 2 each 1 1/4" thick HPL work surfaces with 1 3/4" thick oak edge banding	7739.00

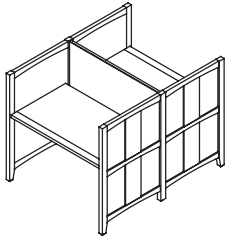

Park Avenue

FULL PANEL CARRELS WITH SQUARE TAPERED LEGS

MODEL NUMBER	DESCRIPTION	LIST PRICE
PS-3148-O-FPDF	Elevated Panel Carrel work station, double faced, starter in oak 61" deep x 50" wide x 48" high, 1 1/8" thick end panels with 2 1/2" high solid oak arched edge banding at the top and bottom of the end panels with horizontal center slat and 5" wide vertical slats, 2" flat end posts tapered from the bottom of the panel to 1 1/2" at the floor, 2 each 1 1/4" thick HPL work surfaces with 1 3/4" thick oak edge banding	10127.00
PS-3148-O-FPDFA	Carrel work station, double faced, adder in oak 61" deep x 48 1/2" wide x 48" high, 1 1/8" thick intermediate panels with arched detailing at the top and bottom of the panels, 2" flat end posts tapered to 1 1/2" at the bottom, 1 1/4" thick HPL work surfaces with 1 3/4" thick oak edge banding	8384.00
SHELF	For each book shelf at 210.00.	
SUFFIX-M	For oak study carrels change suffix M to O and add 7 percent.	

Park Avenue

READING TABLES WITH ROUND TAPERED LEGS

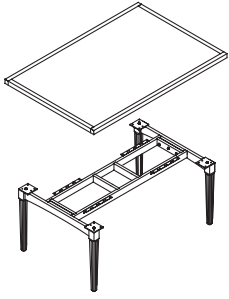

MODEL NUMBER	DESCRIPTION	LIST PRICE
PR-3648-O-T	Table 36" deep x 48" wide in oak, HPL top 1 1/4" thick with 1 3/4" W x 1 5/8" H drop edge banding, 3" arched aprons at each end, 2 3/4" solid oak round legs tapered to 1 1/2" at the bottom with metal leg plates, ladder keel for structural support	4462.00
PR-3060-O-T	Table 30" deep x 60" wide in oak, HPL top 1 1/4" thick with 1 3/4" W x 1 5/8" H drop edge banding, 3" arched aprons at each end, 2 3/4" solid oak round legs tapered to 1 1/2" at the bottom with metal leg plates, ladder keel for structural support	4763.00
PR-3660-O-T	Table 36" deep x 60" wide in oak, HPL top 1 1/4" thick with 1 3/4" W x 1 5/8" H drop edge banding, 3" arched aprons at each end, 2 3/4" solid oak round legs tapered to 1 1/2" at the bottom with metal leg plates, ladder keel for structural support	4877.00
PR-3672-O-T	Table 36" deep x 72" wide in oak, HPL top 1 1/4" thick with 1 3/4" W x 1 5/8" H drop edge banding, 3" arched aprons at each end, 2 3/4" solid oak round legs tapered to 1 1/2" at the bottom with metal leg plates, ladder keel for structural support	5334.00
PR-3696-O-T	Table 36" deep x 96" wide in oak, HPL top 1 1/4" thick with 1 3/4" W x 1 5/8" H drop edge banding, 3" arched aprons at each end, 2 3/4" solid oak round legs tapered to 1 1/2" at the bottom with metal leg plates, ladder keel for structural support	6133.00
PR-4272-O-T	Table 42" deep x 72" wide in oak, HPL top 1 1/4" thick with 1 3/4" W x 1 5/8" H drop edge banding, 3" arched aprons at each end, 2 3/4" solid oak round legs tapered to 1 1/2" at the bottom with metal leg plates, ladder keel for structural support	5534.00
PR-4296-O-T	Table 42" deep x 96" wide in oak, HPL top 1 1/4" thick with 1 3/4" W x 1 5/8" H drop edge banding, 3" arched aprons at each end, 2 3/4" solid oak round legs tapered to 1 1/2" at the bottom with metal leg plates, ladder keel for structural support	6382.00
PR-4872-O-T	Table 48" deep x 72" wide in oak, HPL top 1 1/4" thick with 1 3/4" W x 1 5/8" H drop edge banding, 3" arched aprons at each end, 2 3/4" solid oak round legs tapered to 1 1/2" at the bottom with metal leg plates, ladder keel for structural support	5733.00

Park Avenue

READING TABLES WITH ROUND TAPERED LEGS

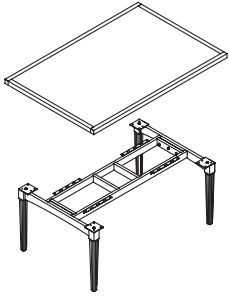

MODEL NUMBER	DESCRIPTION	LIST PRICE
PR-4896-O-T	Table 48" deep x 96" wide in oak, HPL top 1 1/4" thick with 1 3/4" W x 1 5/8" H drop edge banding, 3" arched aprons at each end, 2 3/4" solid oak round legs tapered to 1 1/2" at the bottom with metal leg plates, ladder keel for structural support	6560.00
PR-4242-O-T	Table 42" square in oak, HPL top 1 1/4" thick with 1 3/4" W x 1 5/8" H drop edge banding. 3" arched aprons at each end, 2 3/4" solid oak round legs tapered to 1 1/2" at the bottom with metal leg plates, ladder keel for structural support	4169.00
PR-4848-O-T	Table 48" square in oak, HPL top 1 1/4" thick with 1 3/4" W x 1 5/8" H drop edge banding, 3" arched aprons at each end, 2 3/4" solid oak round legs tapered to 1 1/2" at the bottom with metal leg plates, ladder keel for structural support	4229.00
PR-42R-O-T	Table 42" round in oak, HPL top 1 1/4" thick with 1 3/4" W x 1 5/8" H drop edge banding, 3" arched aprons, 2 3/4" solid oak round legs tapered to 1 1/2" at the bottom with metal leg plates	4742.00
PR-48R-O-T	Table 48" round in oak, HPL top 1 1/4" thick with 1 3/4" W x 1 5/8" H drop edge banding, 3" arched aprons, 2 3/4" solid oak round legs tapered to 1 1/2" at the bottom with metal leg plates	5182.00
PR-60R-O-T	Table 60" round in oak, HPL top 1 1/4" thick with 1 3/4" W x 1 5/8" H drop edge banding, 3" arched aprons, 2 3/4" solid oak round legs tapered to 1 1/2" at the bottom with metal leg plates	5583.00
SUFFIX -M	For maple change the suffix O to M and add 7 percent.	

Park Avenue

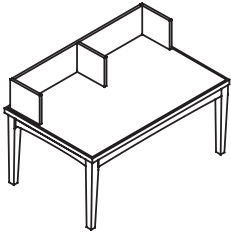

IT TABLES WITH MONITOR RACKS AND ROUND TAPERED LEGS

MODEL NUMBER	DESCRIPTION	LIST PRICE
PR-3036-O-IT	Information technology table 30" deep x 36" wide in oak, HPL top 1 1/4" T with 1 3/4" W x 1 5/8" H drop edge banding, 3" arched aprons at the ends, 2 3/4" solid oak round legs tapered to 1 1/2" at the bottom, metal leg plates and ladder keel, 10" high monitor rack at the back of the table and extending forward 10" at each end	4840.00
PR-3048-O-IT	Information technology table 30" deep x 48" wide in oak, HPL top 1 1/4" T with 1 3/4" W x 1 5/8" H drop edge banding, 3" arched aprons at the ends, 2 3/4" solid oak round legs tapered to 1 1/2" at the bottom, metal leg plates and ladder keel, 10" high monitor rack at the back of the table and extending forward 10" at each end	5024.00
PR-3060-O-IT	Information technology table 30" deep x 60" wide in oak, HPL top 1 1/4" T with 1 3/4" W x 1 5/8" H drop edge banding, 3" arched aprons at the ends, 2 3/4" solid oak round legs tapered to 1 1/2" at the bottom, metal leg plates and ladder keel, 10" high monitor rack at the back of the table and extending forward 10" at each end	5435.00
PR-3072-O-IT	Information technology table 30" deep x 72" wide in oak, HPL top 1 1/4" T with 1 3/4" W x 1 5/8" H drop edge banding, 3" arched aprons at the ends, 2 3/4" solid oak round legs tapered to 1 1/2" at the bottom, metal leg plates and ladder keel, 10" high monitor rack at the back of the table and extending forward 10" at each end	5953.00
PR-3072-O-IT2	Information technology table 30" deep x 72" wide in oak, HPL top 1 1/4" T with 1 3/4" W x 1 5/8" H drop edge banding, 3" arched aprons at the ends, 2 3/4" solid oak round legs tapered to 1 1/2" at the bottom, metal leg plates and ladder keel, 10" high monitor rack at the back of the table and extending forward 10" at each end and the center	6099.00
PR-3096-O-IT2	Information technology table 30" deep x 96" wide in oak, HPL top 1 1/4" T with 1 3/4" W x 1 5/8" H drop edge banding, 3" arched aprons at the ends, 2 3/4" solid oak round legs tapered to 1 1/2" at the bottom, metal leg plates and ladder keel, 10" high monitor rack at the back of the table and extending forward 10" at each end and the center	7009.00
PR-3096-O-IT3	Information technology table 30" deep x 96" wide in oak, HPL top 1 1/4" T with 1 3/4" W x 1 5/8" H drop edge banding, 3" arched aprons at the ends, 2 3/4" solid oak round legs tapered to 1 1/2" at the bottom, metal leg plates and ladder keel, 10" high monitor rack at the back of the table and extending forward 10" at each end and 2 center points dividing the table into 3 equal work spaces	7113.00

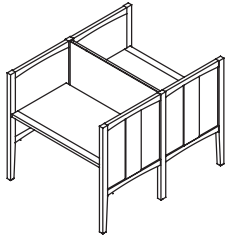

Park Avenue

POST AND PANEL CARRELS WITH ROUND TAPERED LEGS

MODEL NUMBER	DESCRIPTION	LIST PRICE
PR-3136-O-PPSC	Elevated Panel Carrel work station starter in oak 31" deep x 38" wide x 48" high, 1 1/8" thick end panels with 2 1/2" high solid oak arched edge banding at the top and bottom of the panel with 5" wide center slat, 2" round posts tapered from the bottom of the panel to 1 1/2" at the floor, 1 1/4" thick HPL work surface with 1 3/4" thick oak edge banding	4805.00
PR-3136-O-PPSCA	Carrel work station adder in oak 31" deep x 36 1/2" wide x 48" high, 1 1/8" thick intermediate panel with arched detailing at the top and bottom of the panel, 2" round posts tapered from the bottom of the panel to 1 1/2" at the floor, 1 1/4" thick HPL work surface with 1 3/4" thick edge oak banding	3718.00
PR-3150-O-PPSC	Elevated Panel Carrel work station starter in oak 31" deep x 50" wide x 48" high, 1 1/8" thick end panels with 2 1/2" high solid oak arched edge banding at the top and bottom of the panel with 5" wide center slat, 2" round posts tapered from the bottom of the panel to 1 1/2" at the floor, 1 1/4" thick HPL work surface with 1 3/4" thick oak edge banding	5072.00
PR-3148-O-PPSCA	Carrel work station adder in oak 31" deep x 48 1/2" wide x 48" high, 1 1/8" thick intermediate panel with arched detailing at the top and bottom of the panel, 2" round posts tapered from the bottom of the panel to 1 1/2" at the floor, 1 1/4" thick HPL work surface with 1 3/4" thick oak edge banding	3992.00
PR-3136-O-PPDF	Elevated Panel Carrel work station, double faced, starter in oak 61" deep x 38" wide x 48" high, 1 1/8" thick end panels with 2 1/2" high solid oak arched edge banding at top and bottom of panels with 5" wide vertical slat, 2" round posts tapered from the bottom of the panel to 1 1/2" at the floor, 2 each 1 1/4" thick HPL work surfaces with 1 3/4" thick edge banding	7955.00
PR-3136-O-PPDFA	Carrel work station, double faced, adder in oak 61" deep x 36 1/2" wide x 48" high, 1 1/8" thick intermediate panels with arched detailing at the top and bottom of the panel, 2" round posts tapered from the bottom of the panel to 1 1/2" at the floor, 2 each 1 1/4" thick HPL work surfaces with 1 3/4" thick oak edge banding drop	6680.00

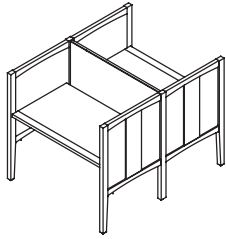

Park Avenue

POST AND PANEL CARRELS WITH ROUND TAPERED LEGS

MODEL NUMBER	DESCRIPTION	LIST PRICE
PR-3148-O-PPDF	Elevated Panel Carrel work station, double faced, starter in oak 61" deep x 50" wide x 48" high, 1 1/8" thick end panels with 2 1/2" high solid oak arched edge banding at top and bottom of panels with 5" wide vertical slat, 2" round posts tapered from the bottom of the panel to 1 1/2" at the floor, 2 each 1 1/4" thick HPL work surfaces with 1 3/4" thick edge oak banding	9509.00
PR-3148-O-PPDFA	Carrel work station, double faced, adder in oak 61" deep x 48 1/2" wide x 48" high, 1 1/8" thick intermediate panels with arched detailing at the top and bottom of the panel at top and bottom of panels, 2" round posts tapered from the bottom of the panel to 1 1/2" at the floor, 2 each 1 1/4" thick HPL work surfaces with 1 3/4" thick edge oak banding	7835.00
SHELF	For each book shelf at 210.00.	
SUFFIX -M	For maple change the suffix O to M and add 7 percent.	

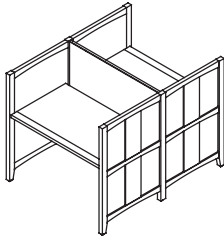

Park Avenue

FULL PANEL CARRELS WITH ROUND TAPERED LEGS

MODEL NUMBER	DESCRIPTION	LIST PRICE
PR-3136-O-FPSC	Elevated Panel Carrel work station starter in oak 31" deep x 38" wide x 48" high, 1 1/8" thick end panels with 2 1/2" high solid oak arched edge banding at the top and bottom of the end panels with horizontal center slat and 5" wide vertical slats, 2" round end posts tapered from the bottom of the panel to 1 1/2" at the floor, 1 1/4" thick HPL work surface with 1 3/4" wide oak edge banding	5357.00
PR-3136-O-FPSCA	Carrel work station adder in oak 31" deep x 36 1/2" wide x 48" high, 1 1/8" thick intermediate panel with arched detailing at the top and bottom of the panel, 2" round posts tapered from the bottom of the panel to 1 1/2" at the floor, 1 1/4" thick HPL work surface with 1 3/4" thick oak edge banding	4334.00
PR-3150-O-FPSC	Elevated Panel Carrel work station starter in oak 31" deep x 50" wide x 48" high, 1 1/8" thick end panels with 2 1/2" high solid oak arched edge banding at the top and bottom of the end panels with horizontal center slat and 5" wide vertical slats, 2" round end posts tapered from the bottom of the panel to 1 1/2" at the floor, 1 1/4" thick HPL work surface with 1 3/4" wide oak edge banding	5683.00
PR-3148-O-FPSCA	Carrel work station adder in oak 31" deep x 48 1/2" wide x 48" high, 1 1/8" thick intermediate panel with arched detailing at the top and bottom of the panel, 2" round posts tapered from the bottom of the panel to 1 1/2" at the floor, 1 1/4" thick HPL work surface with 1 3/4" thick oak edge banding	4657.00
PR-3136-O-FPDF	Elevated Panel Carrel work station, double faced, starter in oak 61" deep x 38" wide x 48" high, 1 1/8" thick end panels with 2 1/2" high solid oak arched edge banding at the top and bottom of the end panels with horizontal center slat and 5" wide vertical slats, 2" round posts tapered from the bottom of the panel to 1 1/2" at the floor, 2 each 1 1/4" thick work surfaces with 1 3/4" thick oak edge banding	8908.00
PR-3136-O-FPDFA	Carrel work station, double faced, adder in oak 61" deep x 36 1/2" wide x 48" high, 1 1/8" thick intermediate panels with arched detailing at the top and bottom of the panel, 2" round posts tapered from the bottom of the to 1 1/2" at the floor, 2 each 1 1/4" thick HPL work surfaces with 1 3/4" thick oak edge banding	7233.00

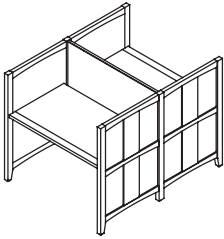

Park Avenue

FULL PANEL CARRELS WITH ROUND TAPERED LEGS

MODEL NUMBER	DESCRIPTION	LIST PRICE
PR-3148-O-FPDF	Elevated Panel Carrel work station, double faced, starter in oak 61" deep x 50" wide x 48" high, 1 1/8" thick end panels with 2 1/2" high solid oak arched edge banding at the top and bottom of the end panel with horizontal slat and 5" wide vertical slats, 2" round posts tapered from the bottom of the panel to 1 1/2" at the floor, 2 each	9509.00
	1 1/4" thick HPL work surfaces with 1 3/4" thick oak edge banding	
PR-3148-O-FPDFA	Carrel work station, double faced, adder in oak 61" deep x 48 1/2" wide x 48" high, 1 1/8" thick intermediate panels with arched detailing at the top and bottom of the panel, 2" round posts tapered to 1 1/2" at the bottom, 1 1/4" thick HPL work surfaces with 1 3/4" thick oak edge banding	7835.00
SHELF	For each book shelf at 210.00.	
SUFFIX -M	For maple change the suffix O to M and add 7 percent.	

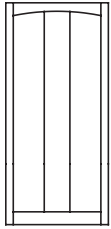

Park Avenue

END PANELS IN OAK

MODEL NUMBER	DESCRIPTION	LIST PRICE
P-4412-DF-O	End panel 44" H x 12" W, 1 1/8" T with 2 1/2" solid oak arched edge banding at top and bottom edges with 2" T edge banding on vertical edges, 5" W center pilaster	1140.00
P-4413-DF-O	End panel 44" H x 13" W, 1 1/8" T with 2 1/2" solid oak arched edge banding at top and bottom edges with 2" T edge banding on vertical edges, 5" W center pilaster	1217.00
P-4414-DF-O	End panel 44" H x 14" W, 1 1/8" T with 2 1/2" solid oak arched edge banding at top and bottom edges with 2" T edge banding on vertical edges, 5" W center pilaster	1292.00
P-4416-DF-O	End panel 44" H x 16" W, 1 1/8" T with 2 1/2" solid oak arched edge banding at top and bottom edges with 2" T edge banding on vertical edges, 5" W center pilaster	1360.00
P-4418-DF-O	End panel 44" H x 18" W, 1 1/8" T with 2 1/2" solid oak arched edge banding at top and bottom edges with 2" T edge banding on vertical edges, 5" W center pilaster	1433.00
P-4420-DF-O	End panel 44" H x 20" W, 1 1/8" T with 2 1/2" solid oak arched edge banding at top and bottom edges with 2" T edge banding on vertical edges, 5" W center pilaster	1529.00
P-4422-DF-O	End panel 44" H x 22" W, 1 1/8" T with 2 1/2" solid oak arched edge banding at top and bottom edges with 2" T edge banding on vertical edges, 5" W center pilaster	1623.00
P-4424-DF-O	End panel 44" H x 24" W, 1 1/8" T with 2 1/2" solid oak arched edge banding at top and bottom edges with 2" T edge banding on vertical edges, 5" W center pilaster	1673.00
P-4425-DF-O	End panel 44" H x 25" W, 1 1/8" T with 2 1/2" solid oak arched edge banding at top and bottom edges with 2" T edge banding on vertical edges, 5" W center pilaster	1745.00
P-4428-DF-O	End panel 44" H x 28" W, 1 1/8" T with 2 1/2" solid oak arched edge banding at top and bottom edges with 2" T edge banding on vertical edges, 5" W center pilaster	1817.00
P-4432-DF-O	End panel 44" H x 32" W, 1 1/8" T with 2 1/2" solid oak arched edge banding at top and bottom edges with 2" T edge banding on vertical edges, 5" W center pilaster	1790.00
P-5012-DF-O	End panel 50" H x 12" W, 1 1/8" T with 2 1/2" solid oak arched edge banding at top and bottom edges with 2" T edge banding on vertical edges, 5" W center pilaster	1222.00

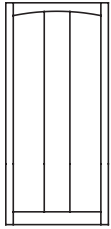

Park Avenue

END PANELS IN OAK

MODEL NUMBER	DESCRIPTION	LIST PRICE
P-5013-DF-O	End panel 50" H x 13" W, 1 1/8" T with 2 1/2" solid oak arched edge banding at top and bottom edges with 2" T edge banding on vertical edges, 5" W center pilaster	1250.00
P-5014-DF-O	End panel 50" H x 14" W, 1 1/8" T with 2 1/2" solid oak arched edge banding at top and bottom edges with 2" T edge banding on vertical edges, 5" W center pilaster	1280.00
P-5016-DF-O	End panel 50" H x 16" W, 1 1/8" T with 2 1/2" solid oak arched edge banding at top and bottom edges with 2" T edge banding on vertical edges, 5" W center pilaster	1338.00
P-5018-DF-O	End panel 50" H x 18" W, 1 1/8" T with 2 1/2" solid oak arched edge banding at top and bottom edges with 2" T edge banding on vertical edges, 5" W center pilaster	1464.00
P-5020-DF-O	End panel 50" H x 20" W, 1 1/8" T with 2 1/2" solid oak arched edge banding at top and bottom edges with 2" T edge banding on vertical edges, 5" W center pilaster	1605.00
P-5022-DF-O	End panel 50" H x 22" W, 1 1/8" T with 2 1/2" solid oak arched edge banding at top and bottom edges with 2" T edge banding on vertical edges, 5" W center pilaster	1648.00
P-5024-DF-O	End panel 50" H x 24" W, 1 1/8" T with 2 1/2" solid oak arched edge banding at top and bottom edges with 2" T edge banding on vertical edges, 5" W center pilaster	1695.00
P-5025-DF-O	End panel 50" H x 25" W, 1 1/8" T with 2 1/2" solid oak arched edge banding at top and bottom edges with 2" T edge banding on vertical edges, 5" W center pilaster	1764.00
P-5028-DF-O	End panel 50" H x 28" W, 1 1/8" T with 2 1/2" solid oak arched edge banding at top and bottom edges with 2" T edge banding on vertical edges, 5" W center pilaster	1848.00
P-5032-DF-O	End panel 50" H x 32" W, 1 1/8" T with 2 1/2" solid oak arched edge banding at top and bottom edges with 2" T edge banding on vertical edges, 5" W center pilaster	2143.00
P-6612-DF-O	End panel 66" H x 12" W, 1 1/8" T with 2 1/2" solid oak arched edge banding at top and bottom edges with 2" T edge banding on vertical edges, 5" W center pilaster	1387.00
P-6613-DF-O	End panel 66" H x 13" W, 1 1/8" T with 2 1/2" solid oak arched edge banding at top and bottom edges with 2" T edge banding on vertical edges, 5" W center pilaster	1412.00

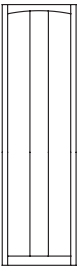

Park Avenue

END PANELS IN OAK

MODEL NUMBER	DESCRIPTION	LIST PRICE
P-6614-DF-O	End panel 66" H x 14" W, 1 1/8" T with 2 1/2" solid oak arched edge banding at top and bottom edges with 2" T edge banding on vertical edges, 5" W center pilaster	1443.00
P-6616-DF-O	End panel 66" H x 16" W, 1 1/8" T with 2 1/2" solid oak arched edge banding at top and bottom edges with 2" T edge banding on vertical edges, 5" W center pilaster	1494.00
P-6618-DF-O	End panel 66" H x 18" W, 1 1/8" T with 2 1/2" solid oak arched edge banding at top and bottom edges with 2" T edge banding on vertical edges, 5" W center pilaster	1599.00
P-6620-DF-O	End panel 66" H x 20" W, 1 1/8" T with 2 1/2" solid oak arched edge banding at top and bottom edges with 2" T edge banding on vertical edges, 5" W center pilaster	1830.00
P-6622-DF-O	End panel 66" H x 22" W, 1 1/8" T with 2 1/2" solid oak arched edge banding at top and bottom edges with 2" T edge banding on vertical edges, 5" W center pilaster	1898.00
P-6624-DF-O	End panel 66" H x 24" W, 1 1/8" T with 2 1/2" solid oak arched edge banding at top and bottom edges with 2" T edge banding on vertical edges, 5" W center pilaster	1989.00
P-6625-DF-O	End panel 66" H x 25" W, 1 1/8" T with 2 1/2" solid oak arched edge banding at top and bottom edges with 2" T edge banding on vertical edges, 5" W center pilaster	2033.00
P-6628-DF-O	End panel 66" H x 28" W, 1 1/8" T with 2 1/2" solid oak arched edge banding at top and bottom edges with 2" T edge banding on vertical edges, 5" W center pilaster	2100.00
P-6632-DF-O	End panel 66" H x 32" W, 1 1/8" T with 2 1/2" solid oak arched edge banding at top and bottom edges with 2" T edge banding on vertical edges, 5" W center pilaster	2189.00
P-8412-DF-O	End panel 84" H x 12" W, 1 1/8" T with 2 1/2" solid oak arched edge banding at top and bottom edges with 2" T edge banding on vertical edges, 5" W center pilaster	1765.00
P-8413-DF-O	End panel 84" H x 13" W, 1 1/8" T with 2 1/2" solid oak arched edge banding at top and bottom edges with 2" T edge banding on vertical edges, 5" W center pilaster	1793.00
P-8414-DF-O	End panel 84" H x 14" W, 1 1/8" T with 2 1/2" solid oak arched edge banding at top and bottom edges with 2" T edge banding on vertical edges, 5" W center pilaster	1845.00

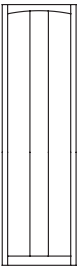

Park Avenue

END PANELS IN OAK

MODEL NUMBER	DESCRIPTION	LIST PRICE
P-8416-DF-O	End panel 84" H x 16" W, 1 1/8" T with 2 1/2" solid oak arched edge banding at top and bottom edges with 2" T edge banding on vertical edges, 5" W center pilaster	1895.00
P-8418-DF-O	End panel 84" H x 18" W, 1 1/8" T with 2 1/2" solid oak arched edge banding at top and bottom edges with 2" T edge banding on vertical edges, 5" W center pilaster	2123.00
P-8420-DF-O	End panel 84" H x 20" W, 1 1/8" T with 2 1/2" solid oak arched edge banding at top and bottom edges with 2" T edge banding on vertical edges, 5" W center pilaster	2339.00
P-8422-DF-O	End panel 84" H x 22" W, 1 1/8" T with 2 1/2" solid oak arched edge banding at top and bottom edges with 2" T edge banding on vertical edges, 5" W center pilaster	2450.00
P-8424-DF-O	End panel 84" H x 24" W, 1 1/8" T with 2 1/2" solid oak arched edge banding at top and bottom edges with 2" T edge banding on vertical edges, 5" W center pilaster	2565.00
P-8425-DF-O	End panel 84" H x 25" W, 1 1/8" T with 2 1/2" solid oak arched edge banding at top and bottom edges with 2" T edge banding on vertical edges, 5" W center pilaster	2605.00
P-8428-DF-O	End panel 84" H x 28" W, 1 1/8" T with 2 1/2" solid oak arched edge banding at top and bottom edges with 2" T edge banding on vertical edges, 5" W center pilaster	2673.00
P-8432-DF-O	End panel 84" H x 32" W, 1 1/8" T with 2 1/2" solid oak arched edge banding at top and bottom edges with 2" T edge banding on vertical edges, 5" W center pilaster	2735.00
P-9012-DF-O	End panel 90" H x 12" W, 1 1/8" T with 2 1/2" solid oak arched edge banding at top and bottom edges with 2" T edge banding on vertical edges, 5" W center pilaster	1807.00
P-9013-DF-O	End panel 90" H x 13" W, 1 1/8" T with 2 1/2" solid oak arched edge banding at top and bottom edges with 2" T edge banding on vertical edges, 5" W center pilaster	1844.00
P-9014-DF-O	End panel 90" H x 14" D, 1 1/8" T with 2 1/2" solid oak arched edge banding at top and bottom edges with 2" T edge banding on vertical edges, 5" W center pilaster	1900.00
P-9016-DF-O	End panel 90" H x 16" D, 1 1/8" T with 2 1/2" solid oak arched edge banding at top and bottom edges with 2" T edge banding on vertical edges, 5" W center pilaster	1958.00

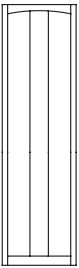

Park Avenue

END PANELS IN OAK

MODEL NUMBER	DESCRIPTION	LIST PRICE
P-9018-DF-O	End panel 90" H x 18" W, 1 1/8" T with 2 1/2" solid oak arched edge banding at top and bottom edges with 2" T edge banding on vertical edges, 5" W center pilaster	2360.00
P-9020-DF-O	End panel 90" H x 20" W, 1 1/8" T with 2 1/2" solid oak arched edge banding at top and bottom edges with 2" T edge banding on vertical edges, 5" W center pilaster	2474.00
P-9022-DF-O	End panel 90" H x 22" W, 1 1/8" T with 2 1/2" solid oak arched edge banding at top and bottom edges with 2" T edge banding on vertical edges, 5" W center pilaster	2565.00
P-9024-DF-O	End panel 90" H x 24" W, 1 1/8" T with 2 1/2" solid oak arched edge banding at top and bottom edges with 2" T edge banding on vertical edges, 5" W center pilaster	2632.00
P-9025-DF-O	End panel 90" H x 25" W, 1 1/8" T with 2 1/2" solid oak arched edge banding at top and bottom edges with 2" T edge banding on vertical edges, 5" W center pilaster	2675.00
P-9028-DF-O	End panel 90" H x 28" W, 1 1/8" T with 2 1/2" solid oak arched edge banding at top and bottom edges with 2" T edge banding on vertical edges, 5" W center pilaster	2744.00
P-9032-DF-O	End panel 90" H x 32" W, 1 1/8" T with 2 1/2" solid oak arched edge banding at top and bottom edges with 2" T edge banding on vertical edges, 5" W center pilaster	2790.00
SUFFIX-M	For maple change the suffix O to M and add 7 percent.	

Park Avenue

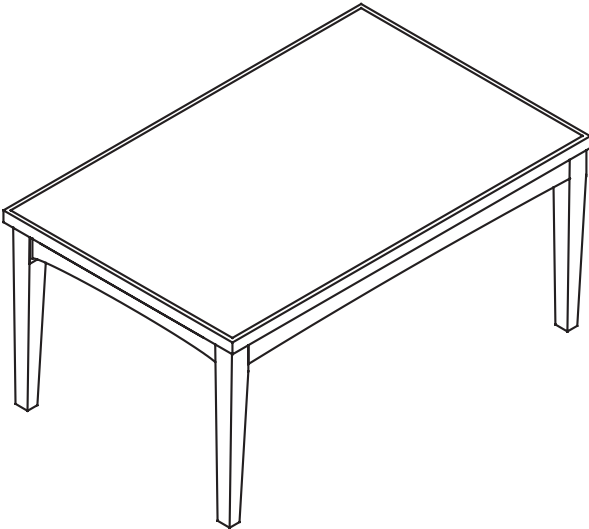

Reading table with square tapered legs and arched aprons

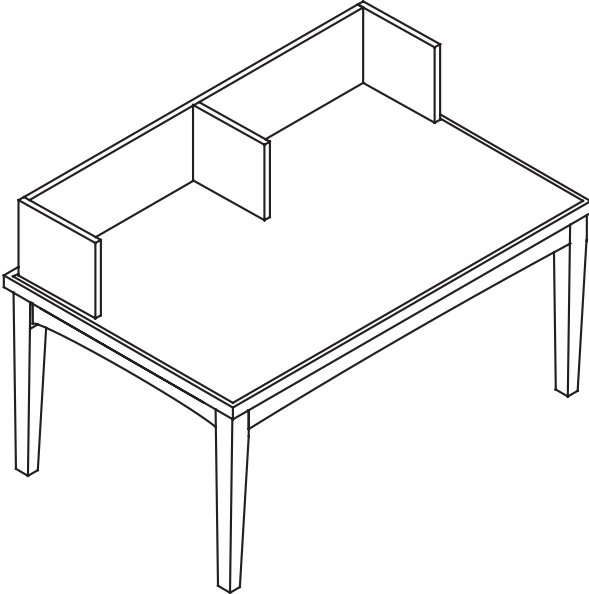

IT table with monitor racks, square tapered legs and arched aprons

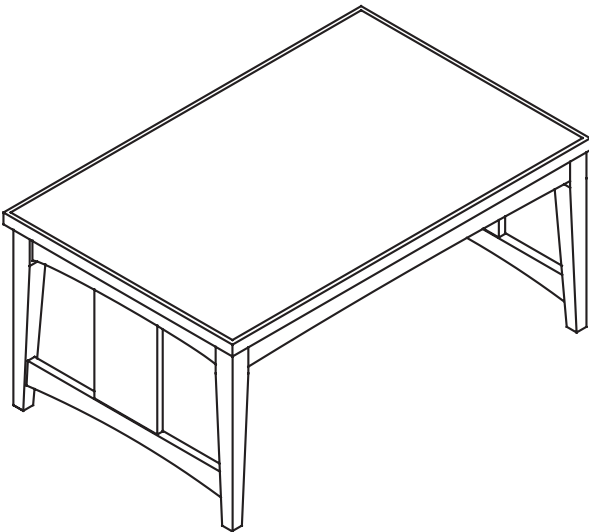

Reading table with square tapered legs, Sentinel ends and arched aprons

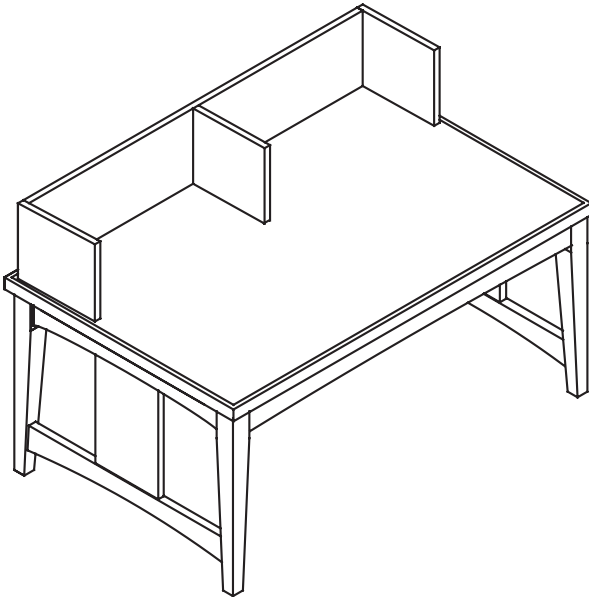

IT table with Sentinel ends, monitor racks, square tapered legs and arched aprons



Park Avenue

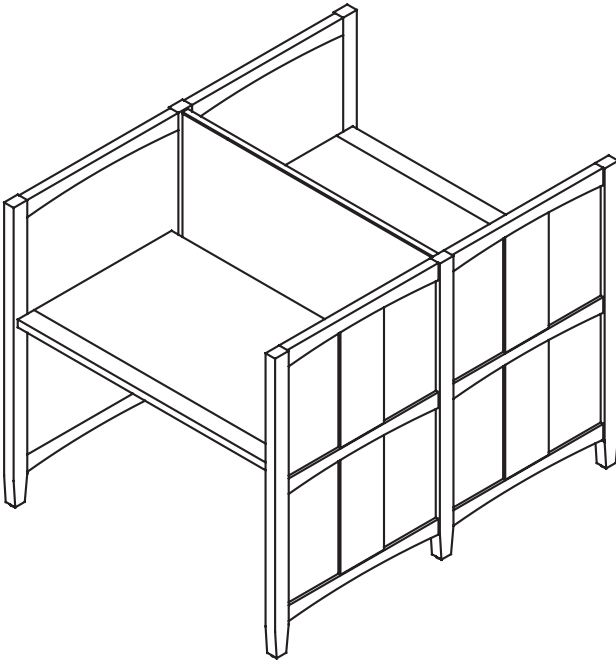

Full panel carrel with square tapered legs

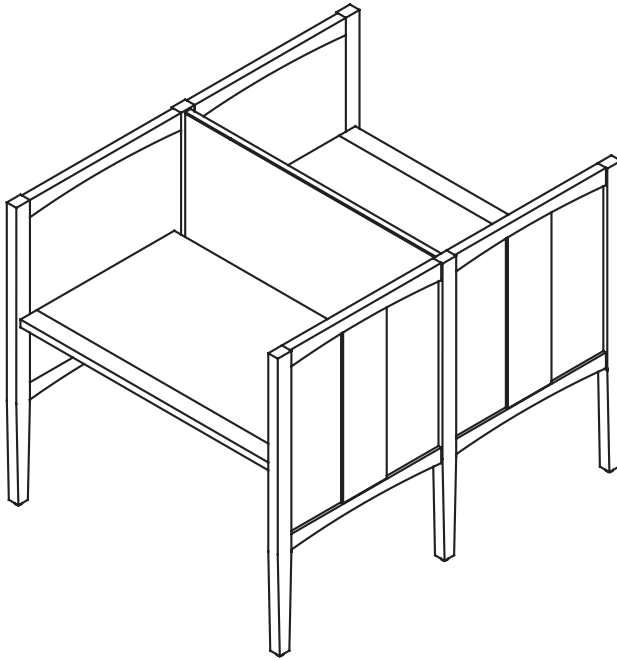

Post and panel carrel with square tapered legs

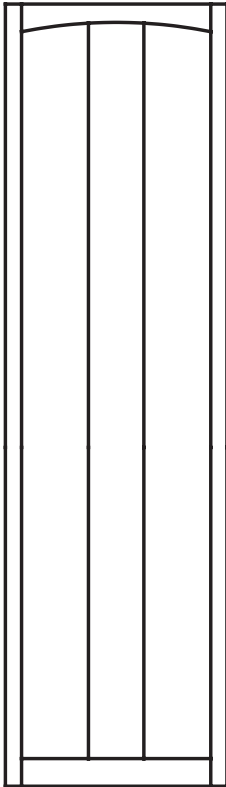

60" or above wood end panel

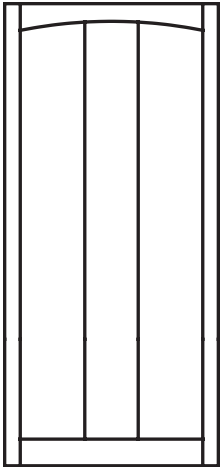

Wood end panel up to 48"

Park Avenue

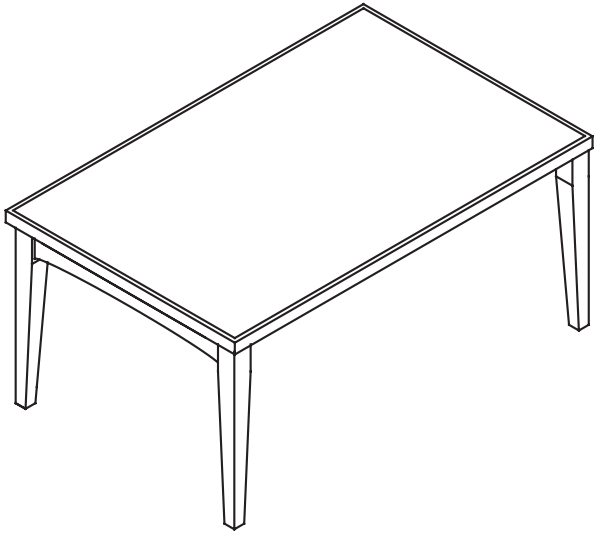

ADA Reading table with square tapered legs and arched aprons

